

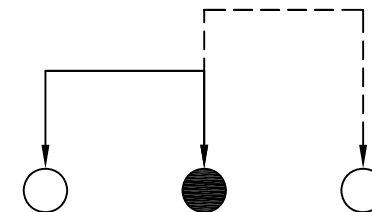

CAD FILE:

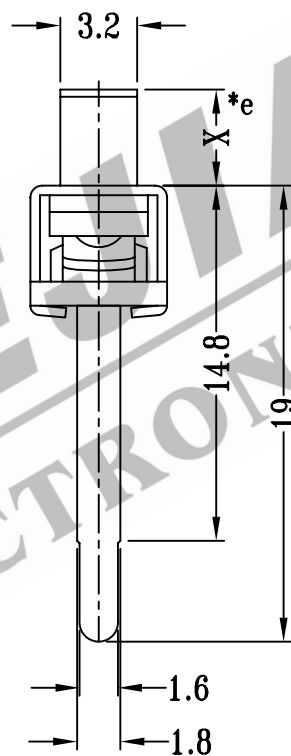

SCHEMATIC (NON-SHORTING)

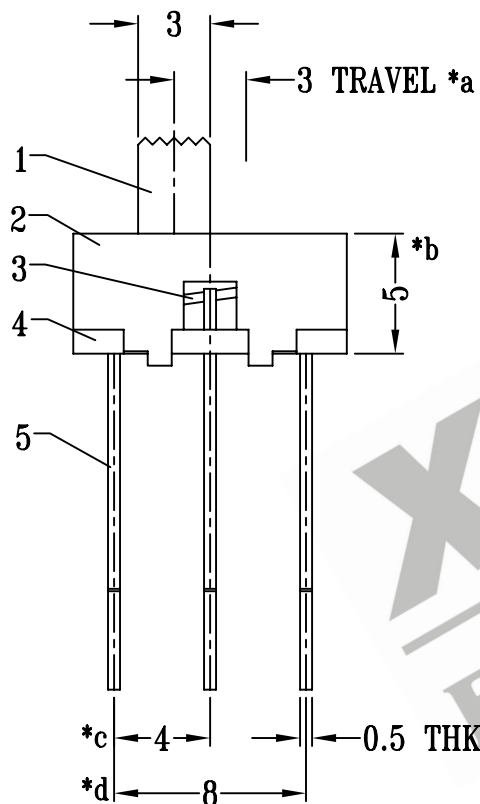
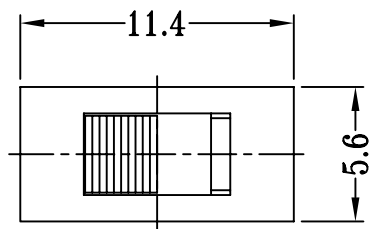
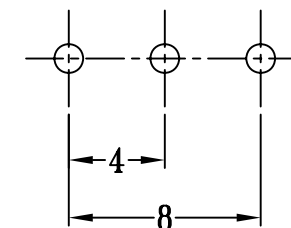

P.C.B LAYOUT

注:带"*"表示关键尺寸(5个)

NO.	PARTS	MATERIALS	Q'TY	FINISH	TOLERANCE UNLESS SPECIFIED	SHENZHEN XIEJIA ELECTRONICS CO.,LTD.					
8						ISSUE		DATE		DESCRIPTIONS OF REVISION	APPD.
7	SPRING	STEEL WIRE	1	TEMPER	WITHIN: 1.5±0.1mm OVER: 1.5±0.2mm	TITLE : VERTICAL SLIDE SWITCH		UNIT : mm	DRWG NO.: XJ-DR-SS12F53-00		
6	STEEL BALL	STEEL	1	NATURAL		MODEL: SS-12F53		SCALE: 3 : 1	DWN.	ZHOUYU	2004-8-23
5	TERMINAL	BRASS STRIP	3	Ag PLATED OVER Ni PLATED		ALL MATERIALS MUST BE COMPLIANT TO ROHS			CHK'D	FANGYING	2004-8-23
4	BASE	PHENOLIC RESIN	1	NATURAL					APPD.	KANGXINAN	2004-8-23
3	CONTACT CLIP	BRASS STRIP	1	Ag PLATED							
2	FRAME	STEEL STRIP	1	BLACK							
1	KNOB	POM	1	BLACK							